

DATASHEET

■ CAPACITIVE STRETCH SENSOR

SS-Series

High accuracy stretch sensor

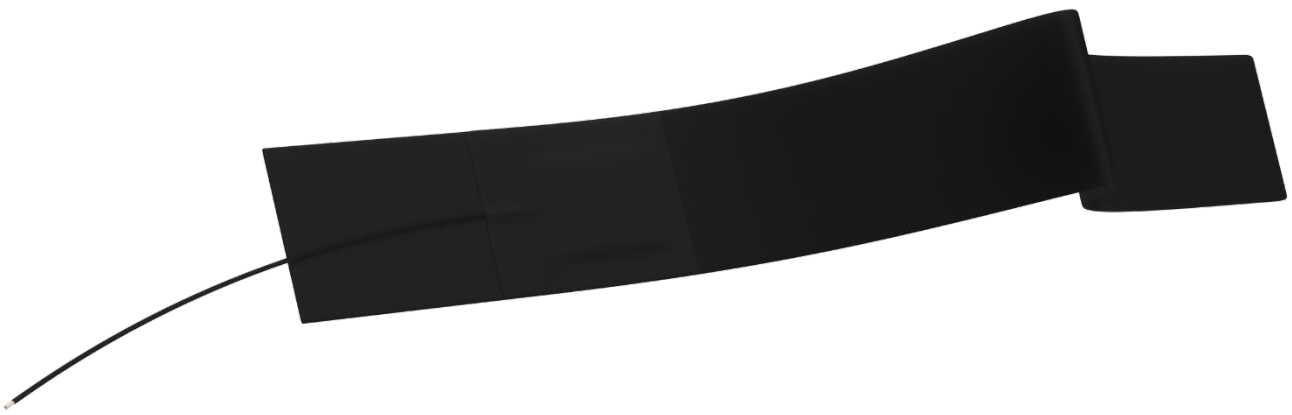

ElastiSense
SENSOR TECHNOLOGY

elastisense.com

CONTENTS

Product description	3
Part number	4
Features and options	5
Specifications	6
Product dimensions	7
Electrical connections	7
Customisation	8
Contact	9

ISS – High accuracy stretch sensor

PRODUCT DESCRIPTION

The ElastiSense Sensor Technology Stretch Sensor is a versatile, highly repeatable, elastic sensor, sensitive to the amount of stretch exposed.

Unlike other stretch sensors, our devices behave predictably over a wide temperature range and do not suffer from significant drift under long periods of use.

The capacitive nature of these products ensures high accuracy and repeatability even in environmentally challenging applications.

The device is available in two standard variants. One of which contains electronics, converting the capacitance directly to a voltage signal, and the other being a bare capacitor which can be measured by the our WE Series electronics. Custom dimensions are also possible to supply (see page 8)

APPLICATION EXAMPLES

- Wearables (smart textiles)
 - Breathing
 - Joint motion
- Geotextiles and membranes
- Large/permanent deformations in metals
- Multi-degree of freedom applications

PART NUMBER

SS-B-80-□□□-C-21 (sensor with built in electronics)

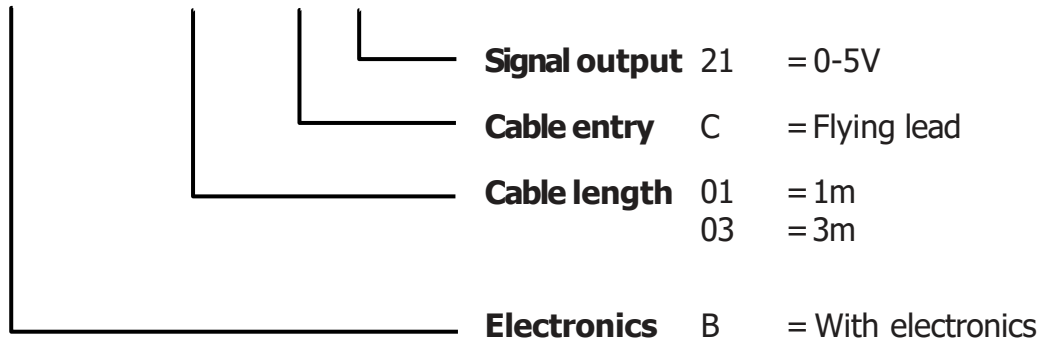

SS-C-80-□□□-U (sensor without electronics)

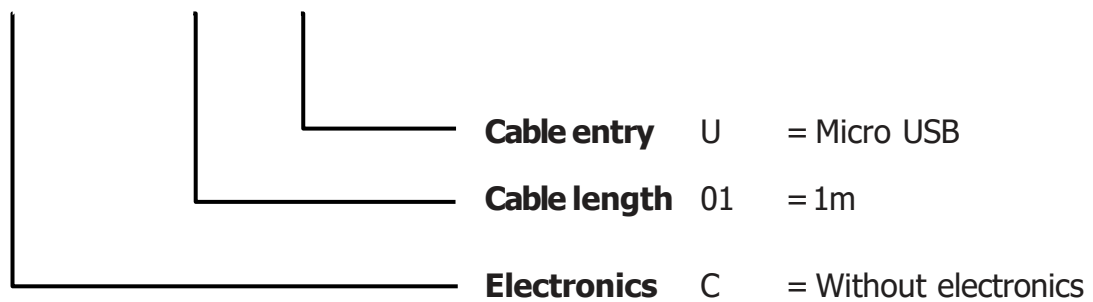

Order SS-C as spare sensors for the WE series measurement electronics

FEATURES AND OPTIONS

SS-B and SS-C

- Can be sewn, glued, screwed or clamped to the application
- Ultra high strain (80% linear strain)
- Low profile
- Tolerant to shock, vibration and misalignment
- Low sensitivity to thickness pressure
- Washable

SS-B additional features

- Flexible voltage supply
- 1000Hz update frequency
- Custom non-linear programming available on request
- Integrated bandpass noise filter

SPECIFICATIONS

Mechanical

Maximum linear stretch	80mm (80%)
Operating temperature	0 to 70°C
Protection rating	Equivalent to IP67
Fatigue life	10 ⁶ cycles @ 80% strain
Weight (not including cable)	<10g

Electrical (SS-B only)

Sensitivity (nominal)	0.05V / mm stretch
Temperature factor	-0.15% / °C
Output signal	0 to 5V
Update rate	1000Hz
Supply voltage	2.25 to 5.25 V
Power consumption	<0.2W

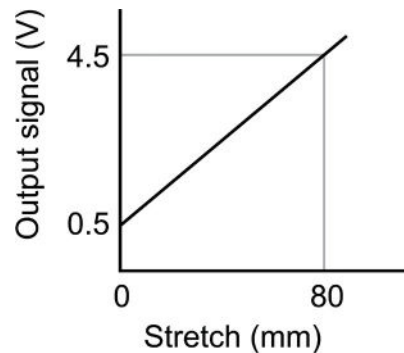

MECHANICAL CONNECTION

Stretch sensors are designed to be attached or tethered by their attachment area. The attachment part of the sensors is made from a nonwoven textile which together with the rest of the sensor, carries the final silicone coating.

It is possible to use sewing, clamping, eyelets for screws and the like for attaching the sensor to its host structure.

As is the case with the SG series strain gauge, stretch sensors can also be glued to a substrate along their entire length. See SG series datasheet for more information.

PRODUCT DIMENSIONS

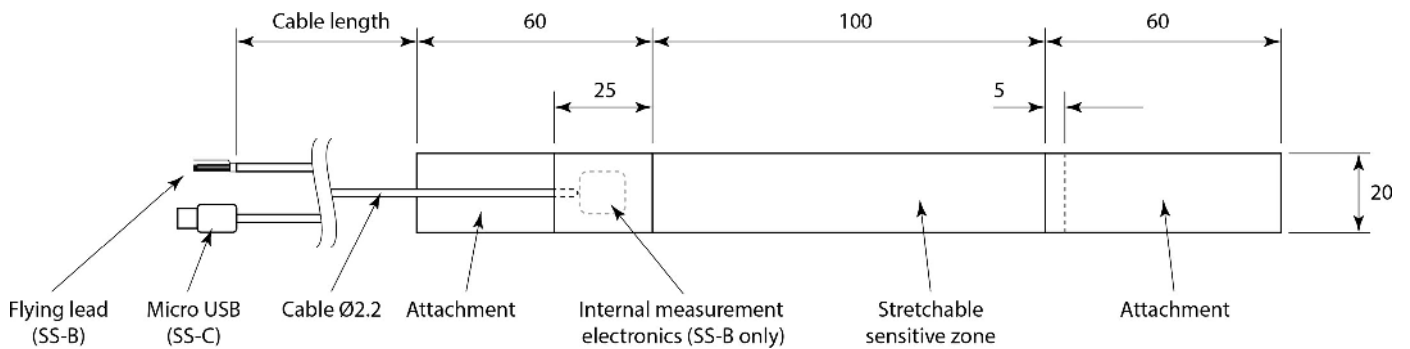

All dimensions in mm and nominal

ELECTRICAL CONNECTIONS

SS-B (with built in electronics)

- 2.5 to 5.25V (supply) - White
- GND (supply) - Yellow
- A_{GND} (signal) - Blue
- A_{OUT} (signal) - Green
- Screen - Uninsulated

SS-C (without electronics)

- Micro USB for connection to LEAP WE electronics

Note:

Signal cable length and environment can affect signal quality. We advise experimentation.

CUSTOMISATION and OPTIONS

It is common for the standard size sensor to be unsuitable for a given application. If this is the case, please refer to the drawing below and contact LEAP with the required dimensions for each of the lines in the table underneath. All dimensions in mm.

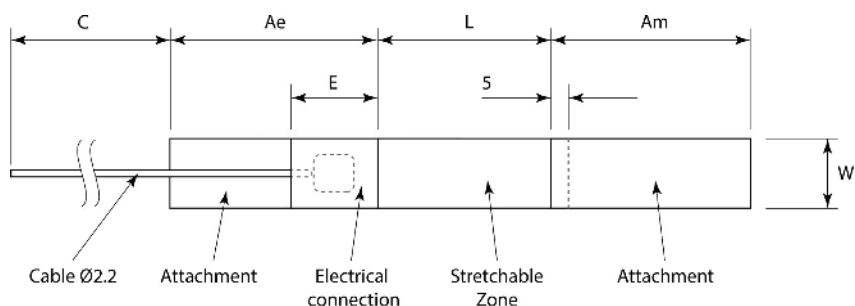

Dimension	Notes	Desired value
Ae	Min 25 (SS-C); Min 30 (SS-B)	
L	Min 5, Max 800	
Am	Min 10 (can be totally removed)	
C	Max 1000 (SS-C); Max 15000 (SS-B)	
E	Min 20 (SS-C); Min 25 (SS-B)	
W	Min 12 (SS-C); Min 15 (SS-B)	

Further options:

- User configurable capacitance range represented by the 0-5V signal
- Other shapes and sizes
- Higher or lower stretch range
- Textile based cabling
- High temperature version (up to 200°C)
- Material samples for attachment testing

CONTACT US

elastisense.com

Bjerndrup Bygade 23, 6200 Aabenraa, Denmark

Phone: +45 20 93 95 48

E-mail: contact@elastisense.com

Terms of Use:

ElastiSense Sensor Technology accepts no responsibility for possible errors caused by inaccuracies in catalogues, brochures, and other material. Due to our policy of continuous product improvement, specifications may change without notice. Modifications may affect any specification of our products. ElastiSense Sensor Technology cannot guarantee product availability and reserves the right to discontinue the product. The user is responsible for determining the suitability of ElastiSense Sensor Technology products for a specific application, for which ElastiSense Sensor Technology offer guidance. All sales are subject to the 'Standard Terms of Sale and Delivery', available on the ElastiSense Sensor Technology website.