

DATASHEET

WIRELESS MEASUREMENT ELECTRONICS

WE-Series

4 channel wireless sensor electronics and software



| CONTENTS

| | | |
|------------------------|-------|---|
| Product description | | 3 |
| Features and options | | 4 |
| Specifications | | 4 |
| Product dimensions | | 5 |
| Electrical connections | | 5 |
| Mechanical connection | | 6 |
| Contact | | 7 |

I WE – 4 channel wireless sensor electronics and software

PRODUCT DESCRIPTION

To get up and running quickly with measuring stretch sensors and strain gauges, ElastiSense Sensor Technology have created a battery powered sensor measurement box and software for reading and recording data.

The device can communicate the sensor signals to the host Windows PC via cable or Bluetooth.

It is specifically designed to measure sensors from EST but can also measure other 3rd part capacitors.

The device is supplied with software which acts as a data acquisition system for sensor signals. It also has simple calibration functionality and a direct visualisation of the sensor signals for convenience.

USAGE EXAMPLES

- Evaluation of technology
- Portable instrumentation
- Prototyping and proof of concept

FEATURES

- Uses simple Micro USB for sensor and power connections
- Choice of update frequency
- Rolling average filter
- Battery for up to 8 hours continuous streaming of data
- Bluetooth connection
- Upgrade to 8 channels available upon request
- Full API available – make your own control software
- Custom developed sensor hardware can be provided to specification, allowing for significant reductions in size. All mechanical features can also be customised.

SPECIFICATIONS

| | |
|----------------------------------|-----------------------------------|
| Power supply | 5V |
| Communication platform | Bluetooth 4.0 and Serial over USB |
| Measurement range | 0.1 to 5nF |
| Output signal update rate | 0.1 to 800Hz |
| Averaging filter range | 4-256 |
| Resolution | 1pF |
| Maximum sensor series resistance | 100kOhm |
| Operating temperature range | 10-60C |
| Protection rating | Equivalent to IP40 |
| Weight (not including cables) | 85g |

PRODUCT DIMENSIONS

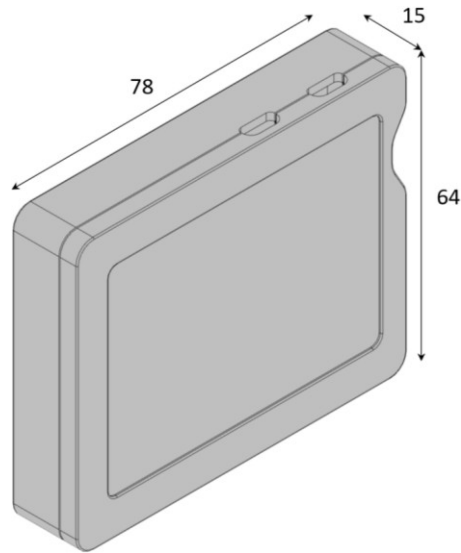

All dimensions in mm and nominal

ELECTRICAL CONNECTIONS

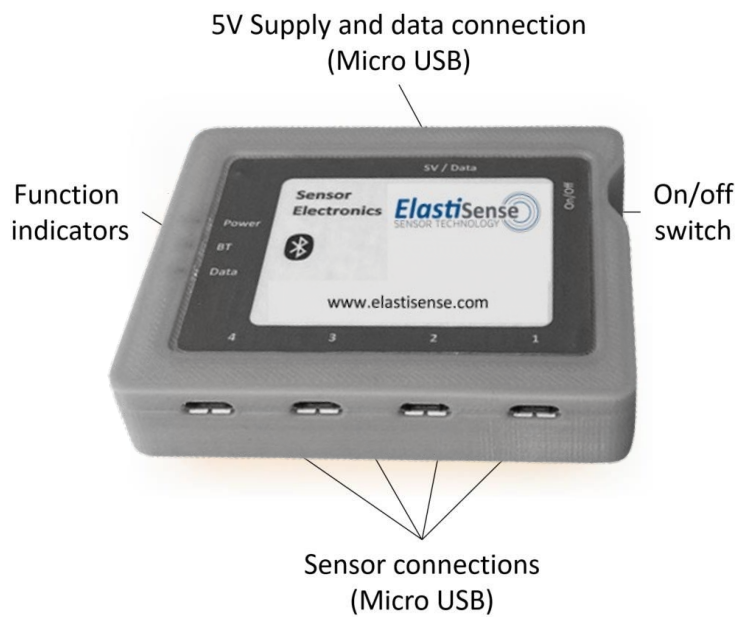

USER INTERFACE

The software supplied with the electronics is suitable for Windows. It presents the data on screen as a graph as well as displaying capacitance values. It can also be calibrated to display and save the data in units of your choice.

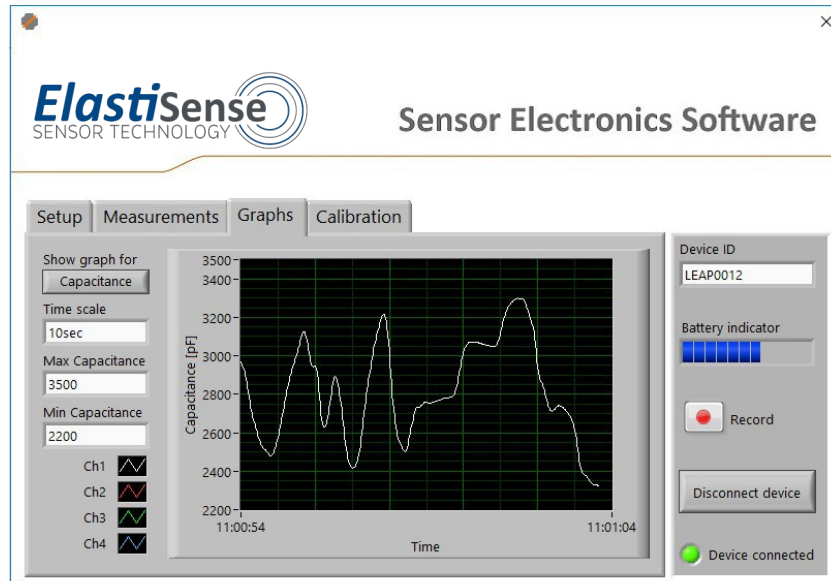



Bjerndrup Bygade23, 6200 Aabenraa,
Denmark
Phone: +45 22447321
E-mail: contact@elastisense.com

ElastiSense Sensor Technology accepts no responsibility for possible errors or inaccuracies in catalogues, brochures, and other material. ElastiSense Sensor Technology reserves the right to change its products without prior notice. ElastiSense Sensor Technology cannot guarantee product availability and reserves the right to discontinue the sale of any product. The user is responsible for determining the suitability of ElastiSense Sensor Technology products for a specific application. All sales are subject to the 'Standard Terms of Sale and Delivery', available on the ElastiSense Sensor Technology website.
