

DATASHEET

| CAPACITIVE STRAIN GAUGE

SG-Series

Hyperelastic elastomer strain gauge



CONTENTS

Product description	3
Part numbering	4
Features and options	5
Specifications	6
Product dimensions	7
Electrical connections	7
Mechanical connection	8
Contact	9

ESG – Hyperelastic elastomer strain gauge

PRODUCT DESCRIPTION

The ElastiSense Sensor Technology Strain Gauge is an elastomeric capacitive strain gauge capable of far exceeding the measurable strain of other gauges.

Unlike other strain gauges, these are made from silicone elastomer, allowing them to be glued or embedded onto or into a large variety of substrates and host materials. They are elastic in all directions.

The capacitive nature of these strain gauges ensures high repeatability even in environmentally challenging applications.

The device is available in two standard variants. One of which contains electronics, converting the capacitance directly to a voltage signal, and the other being a bare strain gauge (capacitor) which can be measured by the EST WE series measurement electronics.

APPLICATION EXAMPLES

- Logistics and transport (dampers)
- Wearables (smart textiles)
- Antivibration systems - performance
- Geotextiles and membranes
- Large/permanent deformations in metals
- Composites

PART NUMBER

SG-B-□□□-C-21

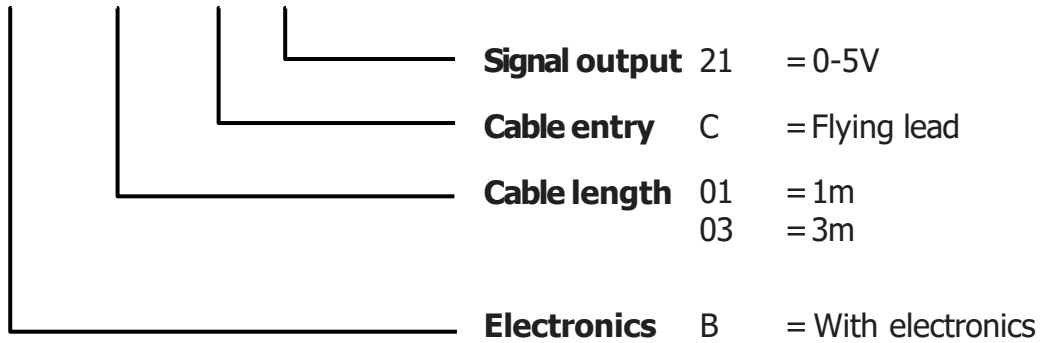

SG-C-□□□-U

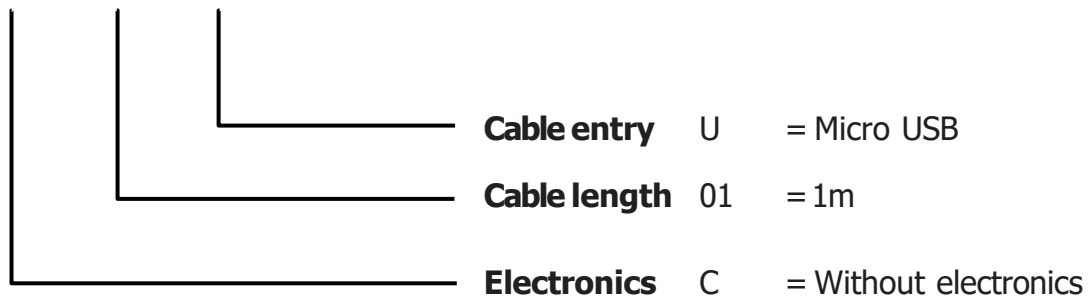

Order SG-C as spare sensors for connection to the WE series measurement electronics

FEATURES AND OPTIONS

SG-B and SG-C

- Can be overmoulded or glued onto the host material
- Sensors resolve area strain
- Ultra high strain (30%)

SG-B additional features

- Flexible voltage supply
- 1000Hz update frequency
- Custom non-linear programming available on request
- Integrated bandpass noise filter

Customisation and options:

- User configurable capacitance range represented by the 0-5V signal
- Other shapes and sizes
- Unidirectional sensing
- High temperature version (up to 200°C)
- Material samples for adhesion testing

SPECIFICATIONS

Mechanical

Maximum area strain	30%
Operating temperature	0 to 70°C
Protection rating	Equivalent to IP67
Fatigue life	10 ⁶ cycles @ 80% strain
Weight (not including cable)	<2g

Electrical (SG-B only)

Sensitivity (nominal, calculated)	0.133V / %area strain
Temperature factor	-0.15% / °C
Output signal	0 to 5V
Update rate	1000Hz
Supply voltage	2.25 to 5.25 V
Power consumption	<0.2W

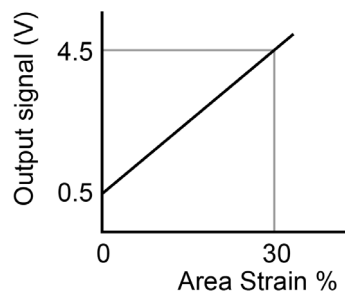

PRODUCT DIMENSIONS

SG-B

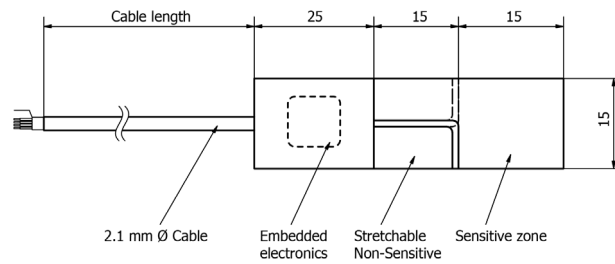

SG-C

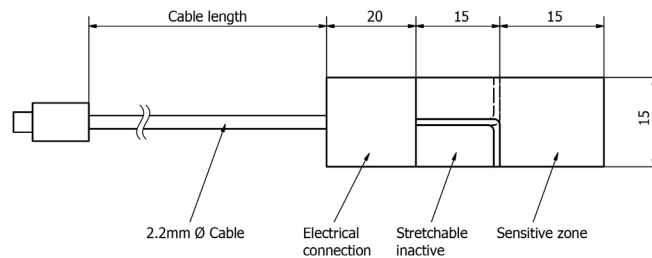

All dimensions in mm and nominal

ELECTRICAL CONNECTIONS

SG-B

- 2.5 to 5.25V (supply) - White
- GND (supply) - Yellow
- A_{GND} (signal) - Blue
- A_{OUT} (signal) - Green
- Screen - Uninsulated

SG-C

- Micro USB for connection to EST WE series measurement electronics

Note:

Signal cable length and environment can affect signal quality. We advise experimentation.

MECHANICAL CONNECTION

The sensitive zone of the sensor is designed to be glued to or embedded into the deforming substrate. ElastiSense Sensor Technology recommend testing the substrate adhesion/encapsulation prior to using the sensors.

- Most thermoplastics, we recommend testing Wacker G790 primer together with Wacker E43 adhesive.
- Natural rubber-based substrates, we recommend just Wacker E43.
- For textiles, the application of adhesive is just as important to consider, as the adhesive it's self in order to get best results. Thorough testing is recommended.

EST can also supply material samples for adhesion testing if required and can also carry out adhesive testing services upon request.

In cases where overmoulding or other forms of encapsulation are desired, exposure to high temperature, pressure and the use of solvents can damage the sensor. We recommend dialogue with EST, together with experimentation with respect to techniques, materials and process conditions.

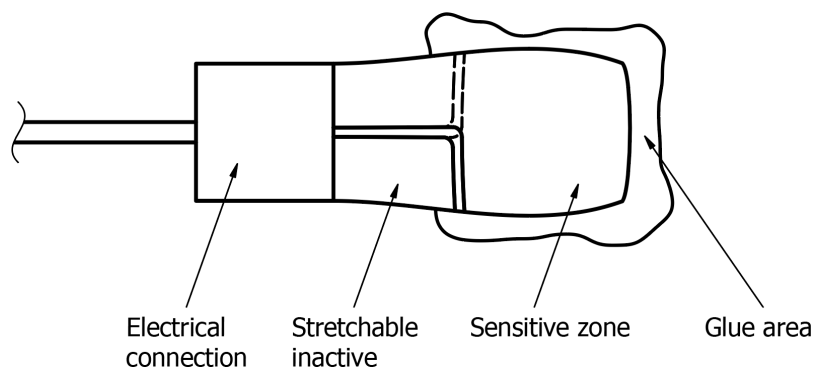

Standard EST gauges return area strain, though the substrate may strain in any predominant direction.

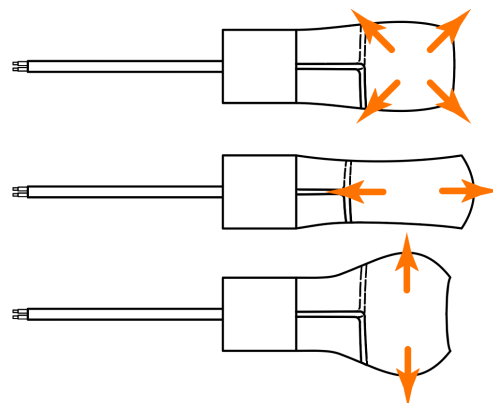

CONTACT US

www.elastisense.com

Bjerndrup Bygade 23, 6200 Aabenraa, Denmark

Phone: +45 20 93 95 48

E-mail: contact@elastisense.com



Terms of Use:

ElastiSense Sensor Technology (EST) accepts no responsibility for possible errors caused by inaccuracies in catalogues, brochures, and other material. Due to our policy of continuous product improvement, specifications may change without notice. Modifications may affect any specification of our products. ElastiSense Sensor Technology cannot guarantee product availability and reserves the right to discontinue the product. The user is responsible for determining the suitability of EST products for a specific application, for which EST offer guidance. All sales are subject to the 'Standard Terms of Sale and Delivery', available on the EST website.